

Vertical Type Electric Servo Drive Injection Molding Machine

JT-ELIII SERIES

Specifications



A Wide Selection

Block Systems

Our JT-EL III series has various modules ready for use. The size, shape, production quantity and mode of a molding part will select the most opportune specification and viable performance of an injection machine currently available, resulting in a precise, steady and enhanced molding production.

Modular Composition

Single acting type

Single acting type				
	M40	M70	M100	Clamping Module
20V				
55V				
110V				
230V				
Injection Module				

Rotary type

Rotary type						
	M20R	M40R	M70R	M100R	M150R	Clamping Module
20V						
55V						
110V						
230V						
Injection Module						

Injection Module

Module #	20V			55V			110V			230V		
Screw code	K	A	B	K	A	B	K	A	B	K	A	B
Screw diameter mm	18	20	22	25	28	32	32	35	40	40	45	50
Screw stroke mm	65			90			110			145		
Theoretical injection capacity cm ³	17	20	25	44	55	72	88	106	138	182	231	285
Injection press. MPa	218	177	146	221	177	135	211	177	135	223	177	143
Holding press. {kgf/cm ² }	{2220}	{1800}	{1490}	{2260}	{1800}	{1380}	{2150}	{1800}	{1380}	{2280}	{1800}	{1460}
Injection speed	300			250			160			160		
Injection rate cm ³ /s	76	94	114	123	154	201	129	154	201	201	254	314
Plasticizing rate kg/h	14	18	22	20	25	30	30	40	50	60	76	88
Screw speed min ⁻¹	500			350			300			250		
Nozzle touch force kN {tf}	14.7 1.5			14.7 1.5			14.7 1.5			14.7 1.5		
Nozzle stroke from platen mm	20			20			20			20		
Type of nozzle	Open nozzle (Tip type)			Open nozzle (Tip type)			Open nozzle (Tip type)			Open nozzle (Tip type)		
Cylinder temp. control	Cylinder 3, Nozzle 1			Cylinder 3, Nozzle 1			Cylinder 3, Nozzle 1			Cylinder 3, Nozzle 1		
Heater wattage kW	3.1			5.4			7.6			12.0		

Clamping Module

Type	Single acting type			Rotary type					
Module #	M40	M70	M100	M20R	M40R	M70R	M100R	M150R	
Clamping system	Bell crank double toggle			Bell crank double toggle					
Clamping force kN {tf}	392 {40}	686 {70}	981 {100}	196 {20}	392 {40}	686 {70}	981 {100}	1470 {150}	
Daylight opening mm	550	600	650	430	470	550	600	650	
Opening stroke mm	250	250	250	200	200	250	250	250	
Mold height (min./max.)	Min. mm Max. mm	200 300	250 350	300 400	150 230	170 270	200 300	250 350	300 400
Distance between tie-bars	width mm depth mm	535 360	550 410	595 460	— —	— —	— —	— —	— —
Mold size (Min.)	width mm depth mm	290 220	290 240	300 280	— —	— —	— —	— —	— —
Mold size (Max.)	width mm depth mm	— —	— —	— —	335 335	335 335	375 375	425 425	480 480
Lower mold weight(max.)kg	—	—	—	225*2Molds	225*2Molds	300*2Molds	400*2Molds	500*2Molds	
Ejector force kN {tf}	18 {1.8}	26 {2.7}	26 {2.7}	18 {1.8}	18 {1.8}	26 {2.7}	26 {2.7}	26 {2.7}	
Ejector stroke mm	40	60	60	40	40	60	60	60	
Ejector type	5points	5points	5points	1point	1point	1point	1point	1point	
Table outside dia. mm	—	—	—	1032	1032	1160	1310	1490	
Locate ring dia. mm	100	100	100	100	100	100	100	100	

Note

1. Theoretical injection capacity is (cross sectional area of cylinder) × (stroke of screw).
2. Plasticizing rate is applied for polystyrene.
3. Screw size B is optional.
4. Maximum mold dimensions of the rotary type are in case of the square. Please consult with our staff, when these dimensions are exceeded in the rectangle or other shapes.
5. 1MPa=10.2kgf/cm², 1kN=0.102tf

Single acting type

Machine Dimensions

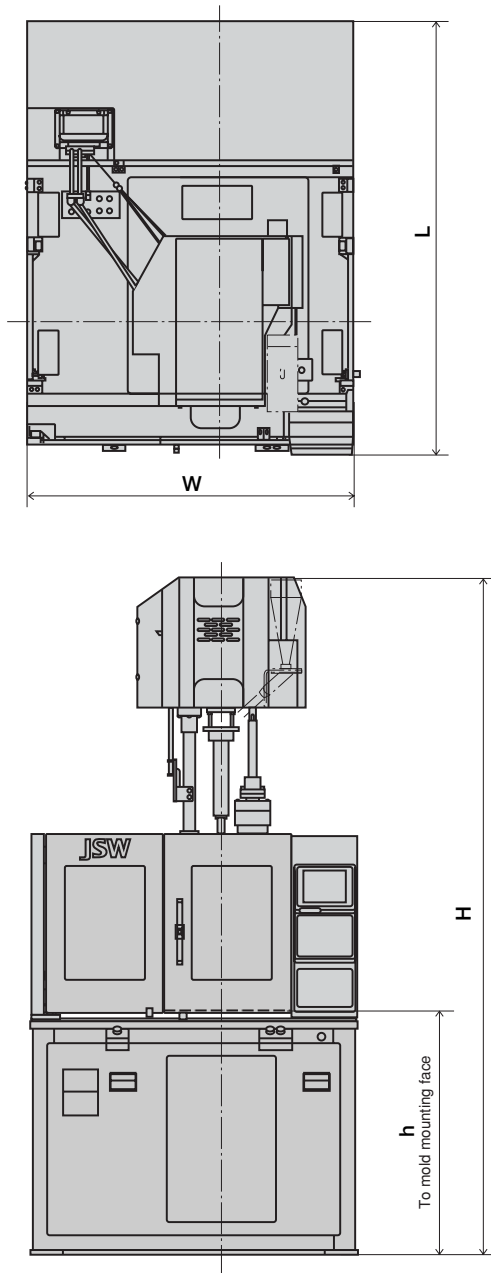

Machine Dimensions

(Unit:mm)

Model	L	W	H		h	Machine weight (t)	
			Min.	Max.			
JT40EL III	20V	1983	1500	2517	3097	1150	3.3
	55V			2702	3282		3.3
	110V			2968	3633		3.6
JT70EL III	55V	2123	1500	2772	3372	1170	4.1
	110V			3038	3723		4.4
	55V			2877	3507		4.9
JT100EL III	110V	2188	1550	3143	3858	1225	5.2
	230V			3481	4216		5.7

Mold Dimensions and Relative Equipment

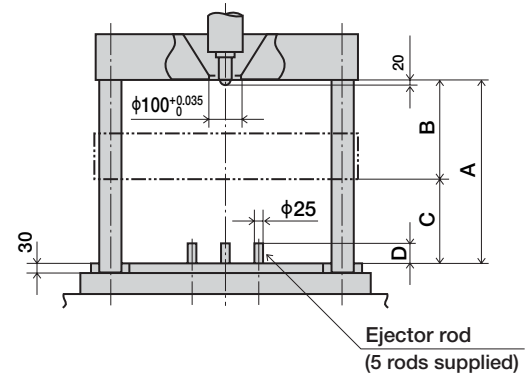

Upper mold side

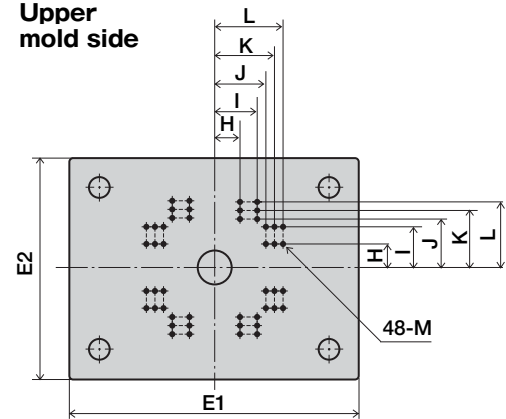

Lower mold side

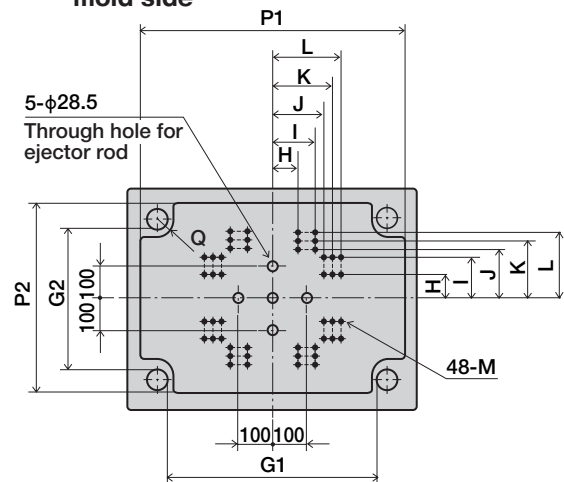

Mold Dimensions and Relative Equipment

(Unit:mm)

Model	A	B	C	D	E1×E2	G1×G2	H
JT40EL III	550	250	200~300	40	710×535	535×360	75
JT70EL III	600	250	250~350	60	760×620	550×410	75
JT100EL III	650	250	300~400	60	840×710	595×460	100

Model	I	J	K	L	M	P1×P2	Q
JT40EL III	100	125	150	175	M16	720×545	50
JT70EL III	125	150	175	200	M16	765×622	55
JT100EL III	150	175	200	225	M16	840×705	60

Rotary type

Machine Dimensions

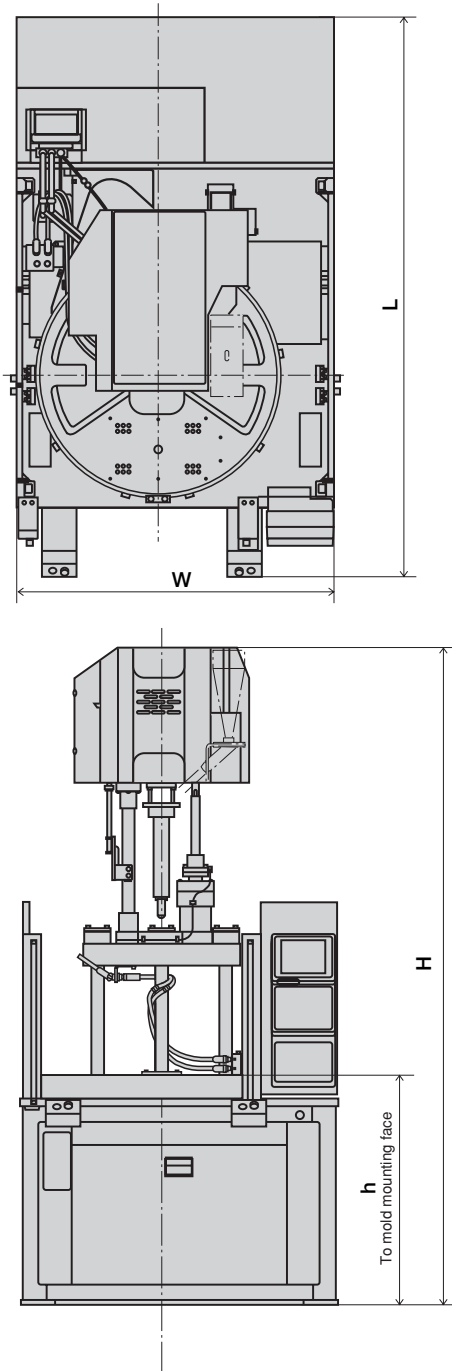

Machine Dimensions

(Unit:mm)

Model		L	W	H		h	Machine weight (t)
				Min.	Max.		
JT20REL III	20V	2427	1370	2312	2802	995	3.2
	55V			2498	2988		3.3
JT40REL III	20V	2427	1370	2332	2852	995	3.3
	55V			2518	3038		3.3
	110V			2783	3388		3.6
JT70REL III	55V	2577	1525	2733	3333	1180	4.3
	110V			2998	3683		4.6
JT100REL III	55V	2772	1675	2838	3468	1235	5.5
	110V			3103	3818		5.8
	230V			3441	4176		6.4
JT150REL III	110V	2967	1810	3268	4003	1350	7.6
	230V			3606	4361		8.2

Mold Dimensions and Relative Equipment

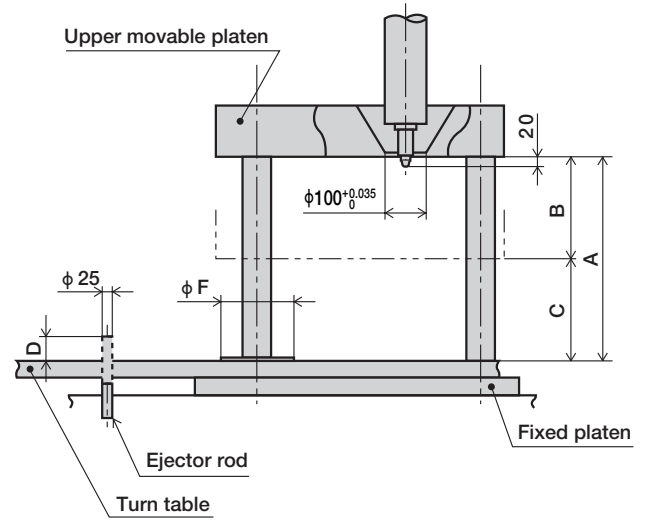

Lower mold side

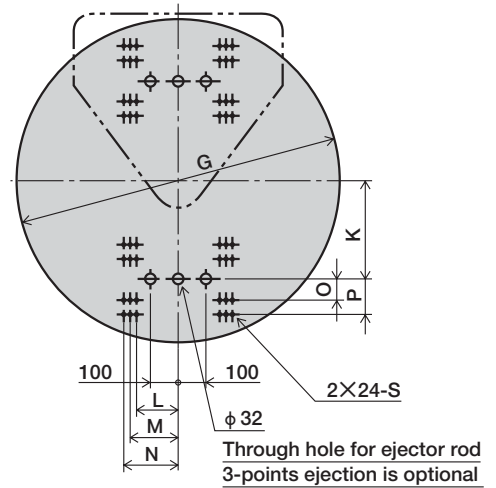

Mold Dimensions and Relative Equipment

(Unit:mm)

Model	A	B	C	D	F	G	K
JT20REL III	430	200	150~230	40	170	1032	320
JT40REL III	470	200	170~270	40	170	1032	320
JT70REL III	550	250	200~300	60	180	1160	360
JT100REL III	600	250	250~350	60	200	1310	405
JT150REL III	650	250	300~400	60	230	1490	465

Model	L	M	N	O	P	S
JT20REL III	100	125	150	50	75	M12
JT40REL III	125	150	175	75	100	M16
JT70REL III	150	175	200	75	125	M16
JT100REL III	175	200	225	100	150	M16
JT150REL III	200	225	250	125	175	M16

Standard Equipment / Optional Equipment

Standard Equipment

Unit Item	
Injection and Plasticizing	Open nozzle (tip type)
	Wear and corrosion-resistant cylinder Note 1)
	Wear and corrosion-resistant screw Note 1)
	HT screw head
	Screw cylinder exchanger
	Cold start-up prevention
	Mold-pause changeover function
	Automatic purging circuit
	Nozzle touch force remote setting
	Nozzle back timing select
	Injection/rotation program control Inj.speed/press,Holding press.: 1~6 steps(adjust.) Screw speed/back press.: 1~6 steps(adjust.)
	Transfer to holding pressure by sensing injection speed(IVS)
	Cylinder temp.remote setting
	Cylinder temp. control (SSR)
	Soft-pack servo control
	Mold Clamping
Automatic greasing	
Mold open/close and ejector program control Mold open/close:1~4 steps(fixed) ejector:1~3 steps(adjust.)	
Automatic mold clamping force setting	
Automatic mold height adjuster	
Remote setting mold height	
Mold protection device	
Safety devices (electrical, and mechanical)Note 2)	
Photocell type safety device(for rotary type only)	
Remote setting of table rotation speed	

Unit Item	
Controller	SYSCOM controller display(touch panel TFT color LCD)
	Japanese/English switching function Note 3)
	Interlock display function
	Injection 2 molding conditions change(for rotary type only)
	Memory of Molding conditions (internal memory 40 molds)
	Data card (40 molds/card)
	Printer output terminal Note 4)
	Self-diagnostic function
	Overall set screen
	Compound actions
Monitor	Cylinder temp. monitoring function
	Heater circuit alarm
	Injection pressure monitor function(IPM)
	Injection wave form monitor
	Injection wave form memory
	Statistical graph function
	Measured value display
	Grease alarm
	Production monitor function Note 5)
	Operating time display function
	Action monitor function
	Molding condition upper/lower limit monitor Note 6)
	Maintenance service Note 7)
History of alarm	
History of set value	
Servo control fault alarm	
Abnormal alarm buzzer	
Other	Mold cooling water closed circuit
	Auxiliary parts (maintenance tools, ejector rod)

Optional Equipment

Optional Item	
Injection	B size screw cylinder
	High accurate nozzle temperature control(2 zone control)
	SVO long nozzle
	High-melter M II screw Note 8)
	LCP resin exclusive screw Note 9)
	Cylinder heat insulation cover
	Shut-off nozzle (pneumatic type)
	Hopper
	Friction ring ceramic
	Sylinder module system
Resin dwell fault alarm	
Mold Clamping	Toggle injection compression function Note 10)
	Daylight extension
	Mold platen heat insulating plate
	Air jet
	Pneumatic core puller circuit
	Unscrewing motor control circuit
	Die clamper
	Ejector for upper mold (hydraulic type)
	Ejector 3 points ejection (rotary type only)
	Ejector stroke extention(rotary type only)
	Mold heater circuit
	Mold temp. control piping for high temp.(rotary type only)
	Quick mold change device
Mold positioning device	
Mold temperature display	
Controller	Language switching function Note 11)
	Calendar timer
	Warning light
	Communication function with host computer(Link10)
	Printer (with printer cable)
	Printer cable (IBM compatible type)
	Data card (40 molds/card)
Robot interface	
Other	Spare plug receptacle
	Flow indicator for cooling water
	Cooling water cut-off alarm
Vibration proof rubbers	

Note 1) Either of the A or K size are standard specification. (B size will be optional.)

Note 2) The operating section of the rotary type shall be a photoelectric type.

Note 3) Japanese/English switching function is standard equipment.

Note 4) The printer unit and cable are optional.

Note 5) The production volume and advanced notice of production complete can be set and expected finish time is displayed.

Note 6) Monitoring functions of the following particulars are equipped as standard.

- Cycle time ○Injection time ○Rotation time ○Mold opening/closing time ○Cushion
- Injection start point ○Changeover position to holding pressure ○Changeover pressure to holding ○Injection pressure ○Screw back pressure

Note 7) Maintenance service time and areas are displayed.

Note 8) Adaptable for screw diameter over 35mm.

Note 9) Adaptable for screw diameter smaller than 28mm.

Note 10) A and B mode are available for injection compression operation, compression can be adjusted in 1-6 steps.

Note 11) One more language can be added, in addition to Japanese and English.

Table of utility

Total Power Capacity

Clamping	Model	Injection module	Total Electric capacity (kVA)
Single acting type	JT40EL III	20V	5.1
		55V	8.1
		110V	11.1
	JT70EL III	55V	8.5
		110V	11.5
	JT100EL III	55V	8.8
		110V	11.8
		230V	18.1
	Rotary type	JT20REL III	20V
55V			9.2
JT40REL III		20V	6.3
		55V	9.2
		110V	12.3
JT70REL III		55V	9.6
		110V	12.6
JT100REL III		55V	10.5
		110V	13.5
		230V	19.7
JT150REL III		110V	14.5
		230V	20.7

Note: Total power capacity does not include external outlets.

Required Water Quantity for Cylinder Hopper

Machine Model	Required Water Quantity for Cylinder Hopper(m ³ /h)
20V	0.3
55V	
110V	
230V	

Note: The above figures do not include the required quantity of water for the mold temperature controller.